

CAD FILE:

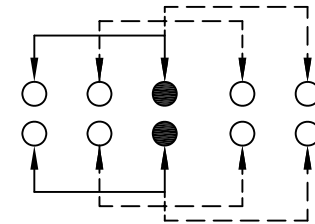

**SCHEMATIC (SHORTING)**

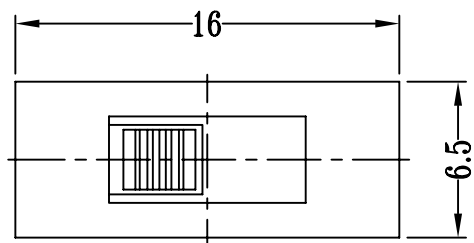
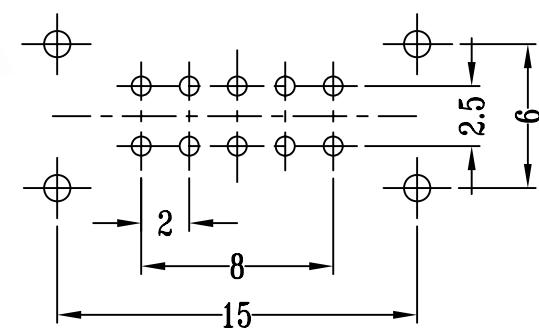
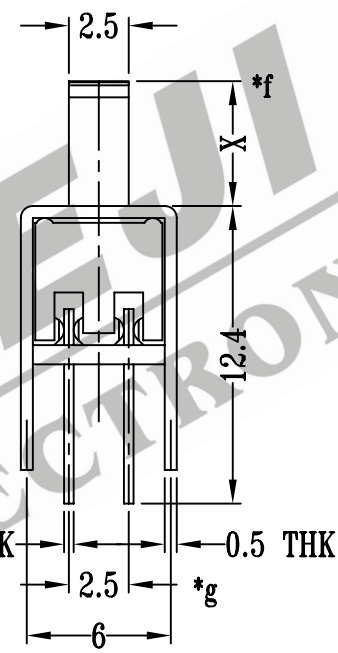
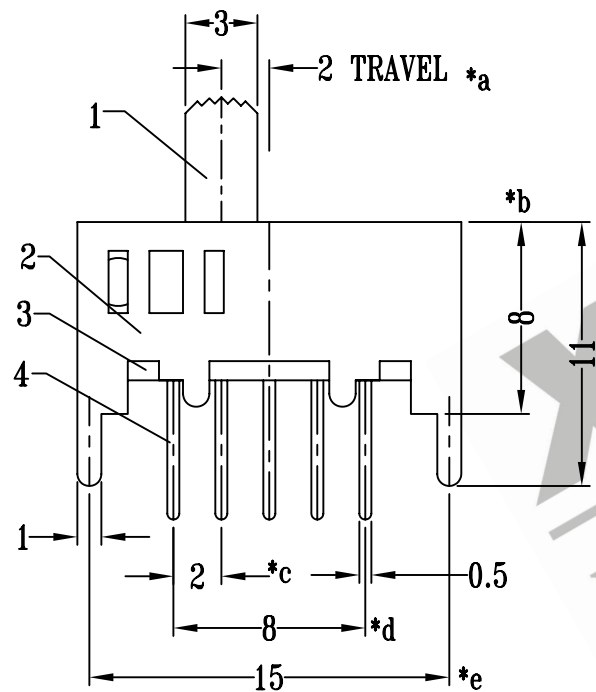

**P.C.B LAYOUT**

注:带"\*"表示关键尺寸(7个)

NO.	PARTS	MATERIALS	Q'TY	FINISH	TOLERANCE UNLESS SPECIFIED	SHENZHEN XIEJIA ELECTRONICS CO.,LTD.				
8						ISSUE		DATE	DESCRIPTIONS OF REVISION	APPD.
7	STEEL BALL	STEEL	1	NATURAL	WITHIN: 1.5±0.1mm OVER : 1.5±0.2mm	TITLE : VERTICAL SLIDE SWITCH		UNIT : mm	DRWG NO.: XJ-DR-SS23D09-00	
6	SPRING	STEEL WIRE	1	TEMPER		MODEL: SS-23D09		SCALE: 3 : 1	DWN. ZHOUYU	2004-6-21
5	CONTACT CLIP	PBS STRIP	2	Ag PLATED		ALL MATERIALS MUST BE COMPLIANT TO ROHS			CHK'D FANGYING	2004-6-21
4	TERMINAL	BRASS STRIP	10	Ag PLATED OVER Ni PLATED					APPD. KANGXINAN	2004-6-21
3	BASE	PHENOLIC RESIN	1	NATURAL						
2	FRAME	STEEL STRIP	1	Ni PLATED						
1	KNOB	POM	1	BLACK						